

Outputs to motors, lights and heaters

(device + to supply +
device - to connector)
CONN1

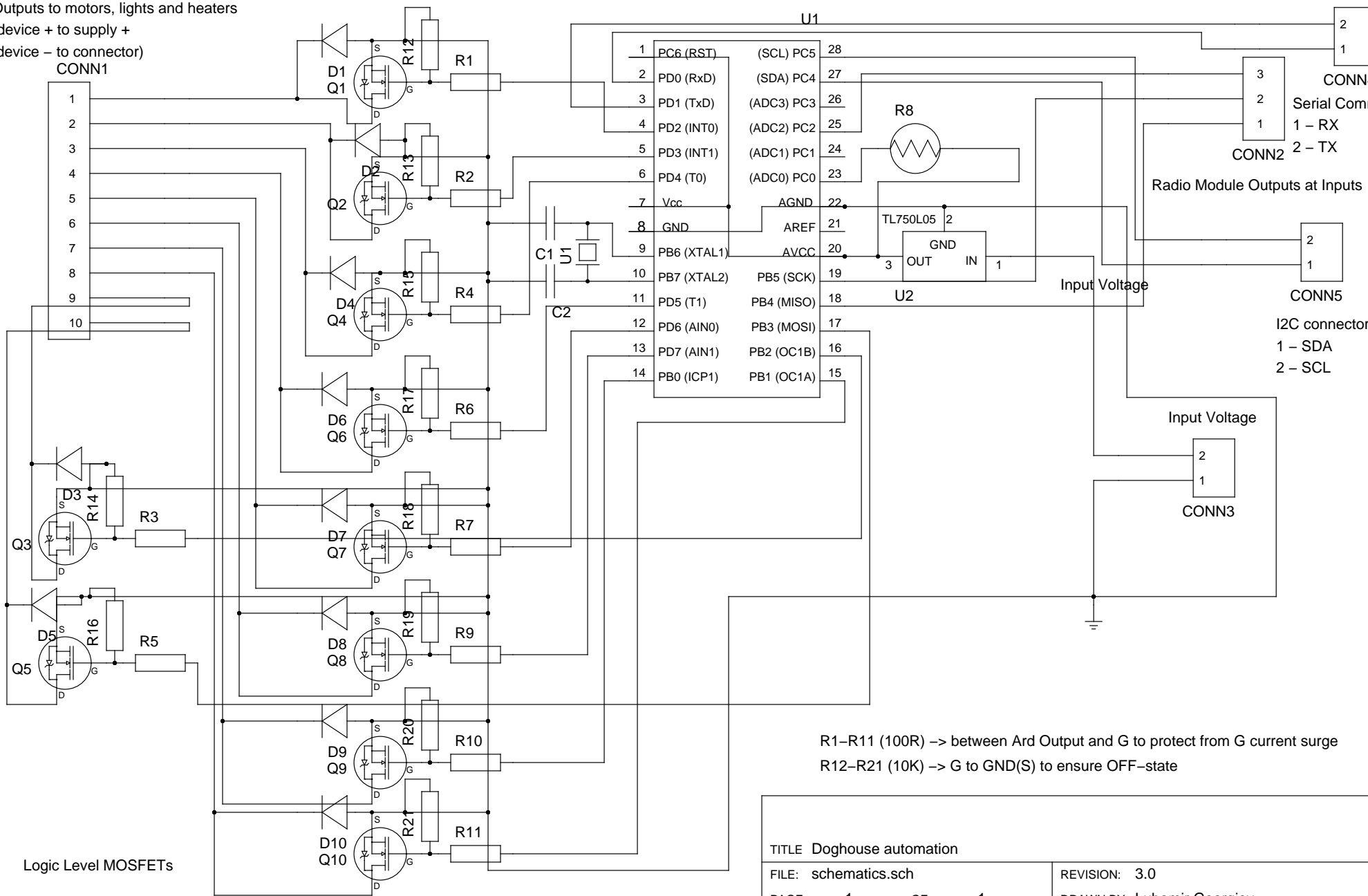

R1-R11 (100R) -> between Ard Output and G to protect from G current surge
R12-R21 (10K) -> G to GND(S) to ensure OFF-state

Logic Level MOSFETs

TITLE Doghouse automation

FILE: schematics.sch

REVISION: 3.0

PAGE 1 OF 1

DRAWN BY: Lubomir Georgiev