

SPECIFICATION

GRAPHIC TYPE

DOT MATRIX LCD MODULE



ITEM NUMBER:	FDCG12864B-NSWBBW-51XN
ESTABLISHED DATE:	1999.06
INITIAL ISSUED DATE:	2004.07
CHECKED BY:	WU WEIJIA
APPROVED BY:	LU BOO

BOOKBINDING AREA



FORDATA ELECTRONIC CO.,LTD
PROFESSIONAL LCD SUPPLIER FROM CHINA

**STANDARD
DOC.**

REVISION RECORD

PAGE

1/17

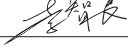
NO.	DATE	DESCRIPTION	ITEM	PAGE	APPROVED
1	2004.07	INITIAL ISSUED	ALL	ALL	WULUBING
2	2007.01	Reduced the current for LED backlight	4	4/20	

BOOKBINDING AREA



FORDATA ELECTRONIC CO.,LTD
PROFESSIONAL LCD SUPPLIER FROM CHINA

**STANDARD
 DOC.**

NUMBER SYSTEM

PAGE

2/17

1	2	3	4	5	6	7	8	9	10	11	12	13	14	15	16
FD	C	C	08	01	A	F	L	Y	Y	B	W	5	2	X	E

No.	REMARKS	DESCRIPTION
1	COMPANY ABBRAVIATED	FD = FORDATA
2	IC packing	C = Chip On Board G = Chip On Glass T = TAB N = NO IC
3	LCM type	C = Character G = Graphic
4	Chyaracter	08, 10, 12, 16, 20, 24, 40, = Character number Per line
	Graphic	80, 100, 120, 122, 128, 160 = Row Dots Quantity
5	Character	01, 02, 04, = Character Lines
	Graphic	32, 64, 80, 128, 160 =Column Dots Quantity
6	Serial Number	A~Z
7	Polarizer type	R = Positive Reflective F = Positive Transflective M = Positive Transmissive N = Negative Transmissive E = Negative, Transflective
8	Backlight type	N = No Backlight S = Edge Type LED Backlight L = Array Type LED Backlight F = EL backlight with Invertor E = EL backlight without Invertor T = CCFL backlight with Invertor C = CCFL backlight without Invertor
9	Backlight color	N = No Backlight Y = Yellow-Green W = White R = Red A = Amber C = Blue-Green B = Blue G = Green
10	LCD panel type	T = TN H = HTN Y = Yellow-Green STN G = Gray STN B = Blue STN F = FSTN
11	Viewing angle	B = Bottom 6:00 T = Top 12:00 R = Right 3:00 L = Left 9:00
12	Operation temperature range	S = 0°C ~ 50°C (Single Supply Voltage) D = 0°C ~ 50°C (Dual Supply Voltage) W = -20°C ~ 70°C (Single Supply Voltage) H = -20°C ~ 70°C (Dual Supply Voltage) T = -30°C ~ 80°C (Single Supply Voltage) E = -30°C ~ 80°C (Dual Supply Voltage)
13	Driving Voltage	1 : V _{lcm} = 3.0V, No / EL / CCFL Backlight or V _{lcm} = 3.0V, V _{led} = LED voltage, (Via AK) 2 : V _{lcm} = 3.6V, V _{led} = 5.0V (Not via AK) 3 : V _{lcm} = 3.6V, V _{led} = LED voltage, (Not via AK) 4 : V _{lcm} = 5.0V, V _{led} = LED voltage, (Not via AK) 5 : V _{lcm} = 5.0V, V _{led} = 5.0V (Not via AK) 6 : V _{lcm} = 5.0V, No / EL / CCFL Backlight or V _{lcm} = 5.0V, V _{led} = LED voltage, (Via AK) 7 : V _{lcm} = 3.6V, No / EL / CCFL Backlight or V _{lcm} = 3.6V, V _{led} = LED voltage, (Via AK) 8 : V _{lcm} = 3.0V, V _{led} = 5.0V 9 : V _{lcm} = 3.0V, V _{led} = LED voltage, (Not via AK)
14	Backlight Connect Method	0 = PIN1 LED-, PIN2 LED+ 1 = PIN15(17/19) LED+, PIN16(18/20) LED- 2 = PIN15(17/19) LED-, PIN16(18/20) LED+ 3 = PIN15(17/19) LED+, PIN16(18/20) NC 4 = PIN15(17/19) NC, PIN16(18/20) LED+ 5 = PINA LED+, PINK LED- 6 = No / EL / CCFL Backlight
15	IC Manufacturer	X = SAMSUNG L = SUNPLUS S = SITRONIX T = TOSHIBA E = EPSON H = HOLTEK Q = ASLIC N = CIMTEK P = PRINCETON
16	Font Set	R = English - Russia E = English - Japanese U = English - Europe H = English - Hebrew K = English - Europe N = NO FONT SET



1. GENERAL SPECIFICATIONS -----	Page 4
2. MECHANICAL SPECIFICATIONS -----	Page 4
3. ABSOLUTE MAXIMUM RATINGS -----	Page 4
4. ELECTRONICAL CHARACTERISTIC -----	Page 4
5. OPTICAL CHARACTERISTICS -----	Page 5
6. DC CHARACTERISTICS -----	Page 6
7. AC CHARACTERISTICS -----	Page 6
8. EXTERNAL DIMENSION-----	Page 8
9. PIN ASSIGNMENT -----	Page 9
10. BLOCK DIAGRAM-----	Page 9
11. POWER SUPPLY -----	Page 9
12. FUNCTIONAL DESCRIPTION -----	Page 10
13. INSTRUCTION -----	Page 13
14. DESCRIPTION OF COMMAND -----	Page 14
15. APPLICATION EXAMPLE -----	Page 16
16. PACKING DETAIL -----	Page 17



1. GENERAL SPECIFICATIONS

ITEM	NOMINAL DIMENSIONS / AVAILABLE OPTIONS
DISPLAY FORMAT	128 X 64 DOT MATRIX
LCD PANEL OPTIONS	STN (Blue color)
POLARIZER OPTIONS	Negative, Transmissive
BACKLIGHT OPTIONS	Edge type LED backlight (White color)
VIEWING ANGLE OPTIONS	6:00 (Bottom)
TEMPERATURE RANGE OPTIONS	Wide temperature range (-20°C ~ 70°C)
CONTROLLER IC	SAMSUNG
NEGATIVE IC	Built in
DISPLAY DUTY	1/64
DRIVING BIAS	1/9

2. MECHANICAL SPECIFICATIONS

OVERALL SIZE	LED backlight version : 93.0 x 70.0 x max 13.0				mm
VIEWING AREA	72.0W x 40.0H	mm	HOLE-HOLE	88.0W x 64.0H	mm
DOT SIZE	0.48W x 0.48H	mm	DOT PITCH	0.04W x 0.04H	mm
WEIGHT (EL BKL)	60.0	g	WEIGHT (LED BKL)	83.0	g

3. ABSOLUTE MAXIMUM RATINGS

ITEM	SYMBOL	CONDITION	MIN	MAX	UNIT
POWER SUPPLY (LOGIC)	Vdd	25°C	-0.3	7.0	V
POWER SUPPLY (LCD)	V0	25°C	Vdd -19.0	Vdd +0.3	V
INPUT VOLTAGE	Vin	25°C	-0.3	Vdd +0.3	V
OPERATING TEMPERATURE	Vopr	—	-20	70	°C
STORAGE TEMPERATURE	Vstg	—	-30	80	°C

4. ELECTRONICAL CHARACTERISTIC

ITEM	SYMBOL	CONDITION	STANDARD			UNIT
			MIN	TYP	MAX	
Input voltage	Vdd	+5V	4.7	5.0	5.5	V
Supply current	Idd	Vdd=5V	—	8.0	—	mA
Recommended LCD driving voltage for normal temp. Version module	Vdd - V0	0°C	—	8.9	—	V
		25°C	—	8.6	—	
		50°C	—	8.5	—	
LED forward voltage	VF	25°C	—	3.0	3.6	V
LED forward current	IF	25°C	—	30.0	40.0	mA

5. OPTICAL CHARACTERISTIC

FOR TN TYPE LCD MODULE (TA=25 °C, Vdd=5.0V ± 0.25V)						
ITEM	SYMBOL	CONDITION	MIN	TYP	MAX	UNIT
VIEWING ANGLE	$\Phi 2 - \Phi 1$	K=4	30	---	---	deg
	θ		25			
CONTRAST RATIO	K	---	---	2	---	---
RESPONSE TIME(RISE)	TR	---	---	120	150	ms
RESPONSE TIME(FALL)	TF	---	---	120	150	ms

FOR STN TYPE LCD MODULE (TA=25 °C, Vdd=5.0V ± 0.25V)						
ITEM	SYMBOL	CONDITION	MIN	TYP	MAX	UNIT
VIEWING ANGLE	$\Phi 2 - \Phi 1$	K=4	40	---	---	deg
	θ		60			
CONTRAST RATIO	K	---	---	6	---	---
RESPONSE TIME(RISE)	TR	---	---	150	250	ms
RESPONSE TIME(FALL)	TF	---	---	150	250	ms

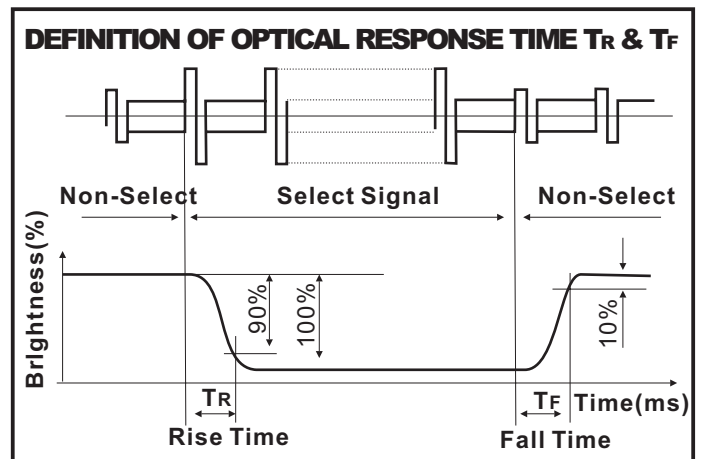
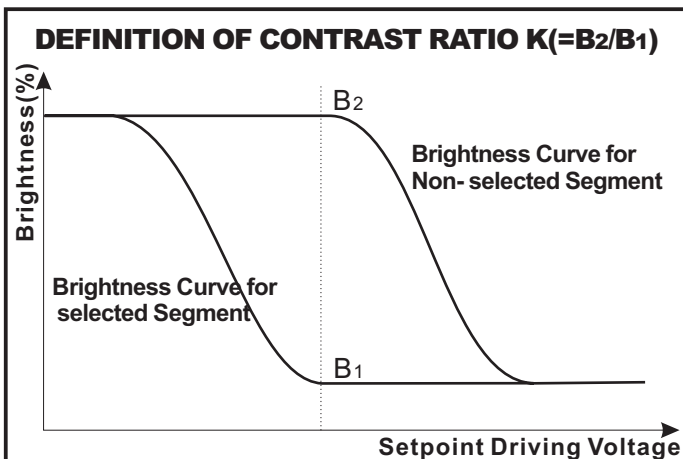
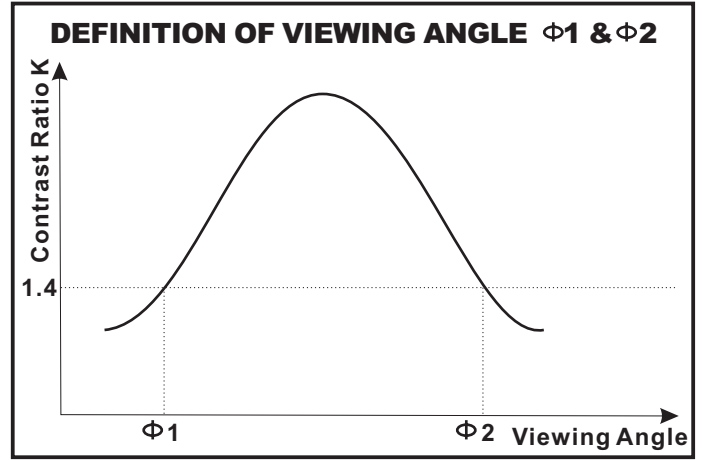
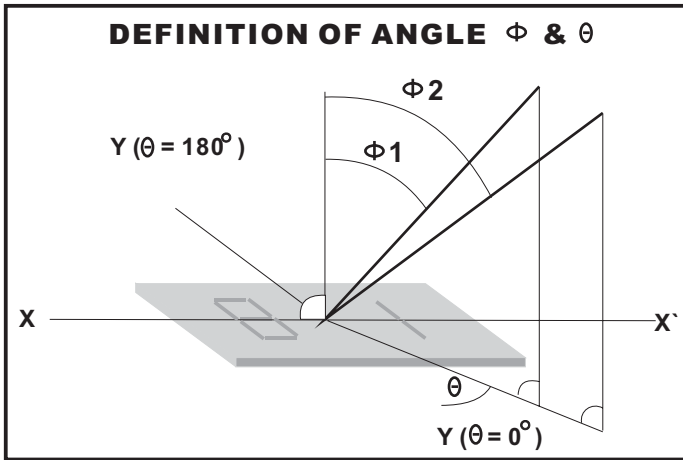

 FORDATA ELECTRONIC CO.,LTD PROFESSIONAL LCD SUPPLIER FROM CHINA	PRODUCT SPEC.	MODE NO.	PAGE	6/17
		FDCG12864B-NSWBBW-51XN		

6. DC CHARACTERISTIC

(Unless otherwise stated, VDD= +5V ± 10%, VSS=0V, Ta=25°C)

Parameter	Symbol	Condition	Min.	Typ.	Max.	Unit
High Level Input Voltage	VIH1	---	0.7VDD	---	VDD	V
	VIH2	---	0.7VDD	---	VDD	V
Low Level Input Voltage	VIL1	---	0	---	0.3VDD	V
	VIL2	---	0	---	0.8	V
High Level Output Voltage	VOH	IOH = - 200 μ A	2.4	---	---	V
Low Level Output Voltage	VOL	IOL = 1.6 mA	---	---	0.4	V
Input Leakage Current	ILKG	VIN = VDD to VSS	-1.0	---	1.0	μ A
Three-State (OFF) Input Current	ITSL	VIN = VDD to VSS	-5.0	---	5.0	μ A
Operating Current	IDD1	During Display	---	---	100	μ A
	IDD2	During Access, Access Cycle = 1MHz	---	---	500	μ A

7. AC CHARACTERISTIC

Characteristic	Symbol	Min	Typ	Max	Unit
E Cycle	t _c	1000	—	—	ns
E High Level Width	t _{WH}	450	—	—	ns
E Low Level Width	t _{WL}	450	—	—	ns
E Rise Time	t _R	—	—	25	ns
E Fall Time	t _F	—	—	25	ns
Address Setup Time	t _{ASU}	140	—	—	ns
Address Hold Time	t _{AH}	10	—	—	ns
Data Setup Time	t _{DSU}	200	—	—	ns
Data Delay Time	t _D	—	—	320	ns
Data Hold Time (Write)	t _{DHW}	10	—	—	ns
Data Hold Time (Read)	t _{DHR}	20	—	—	ns



7.1 WRITE MODE TIMING DIAGRAM

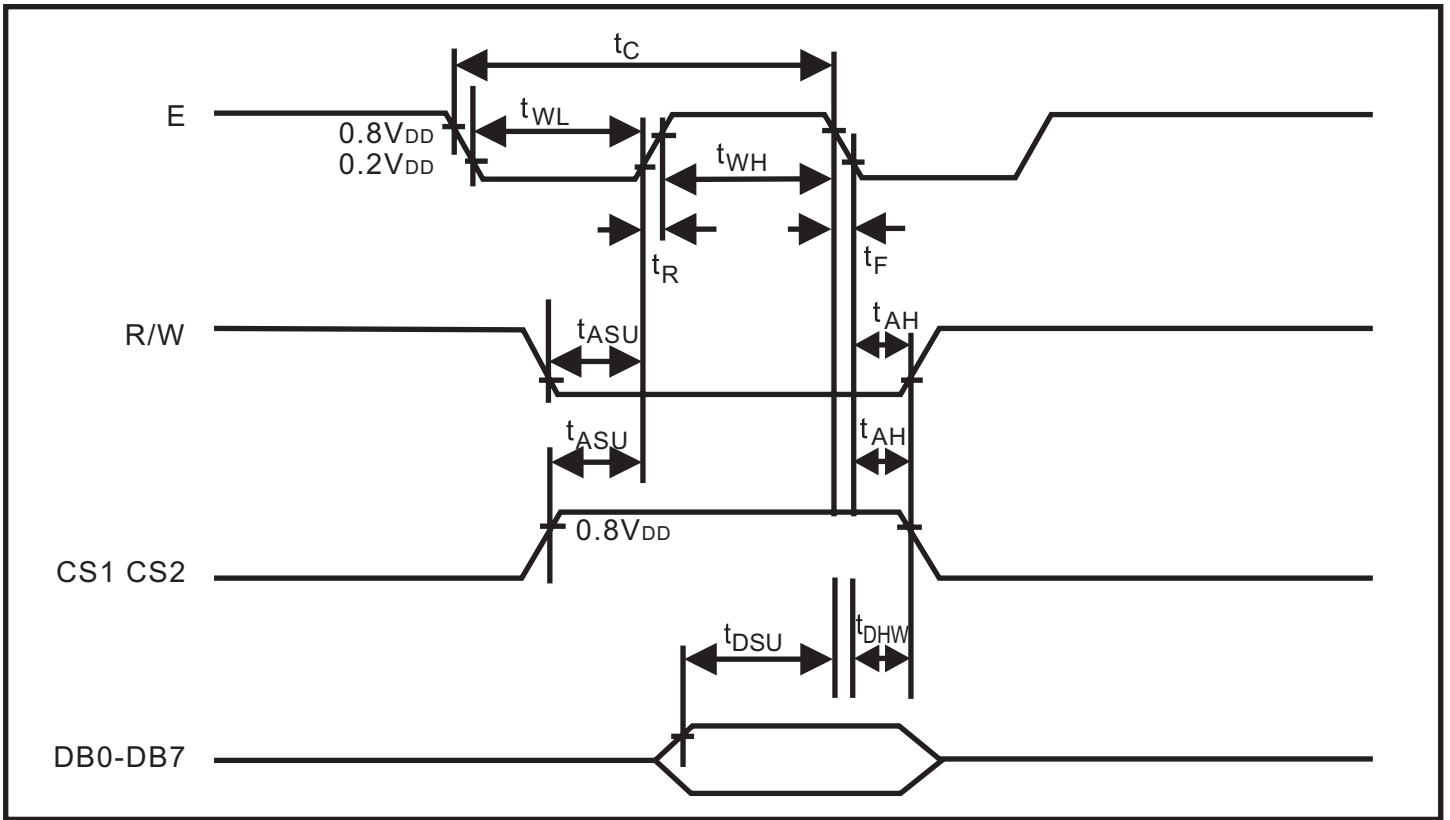

7.2 READ MODE TIMING DIAGRAM

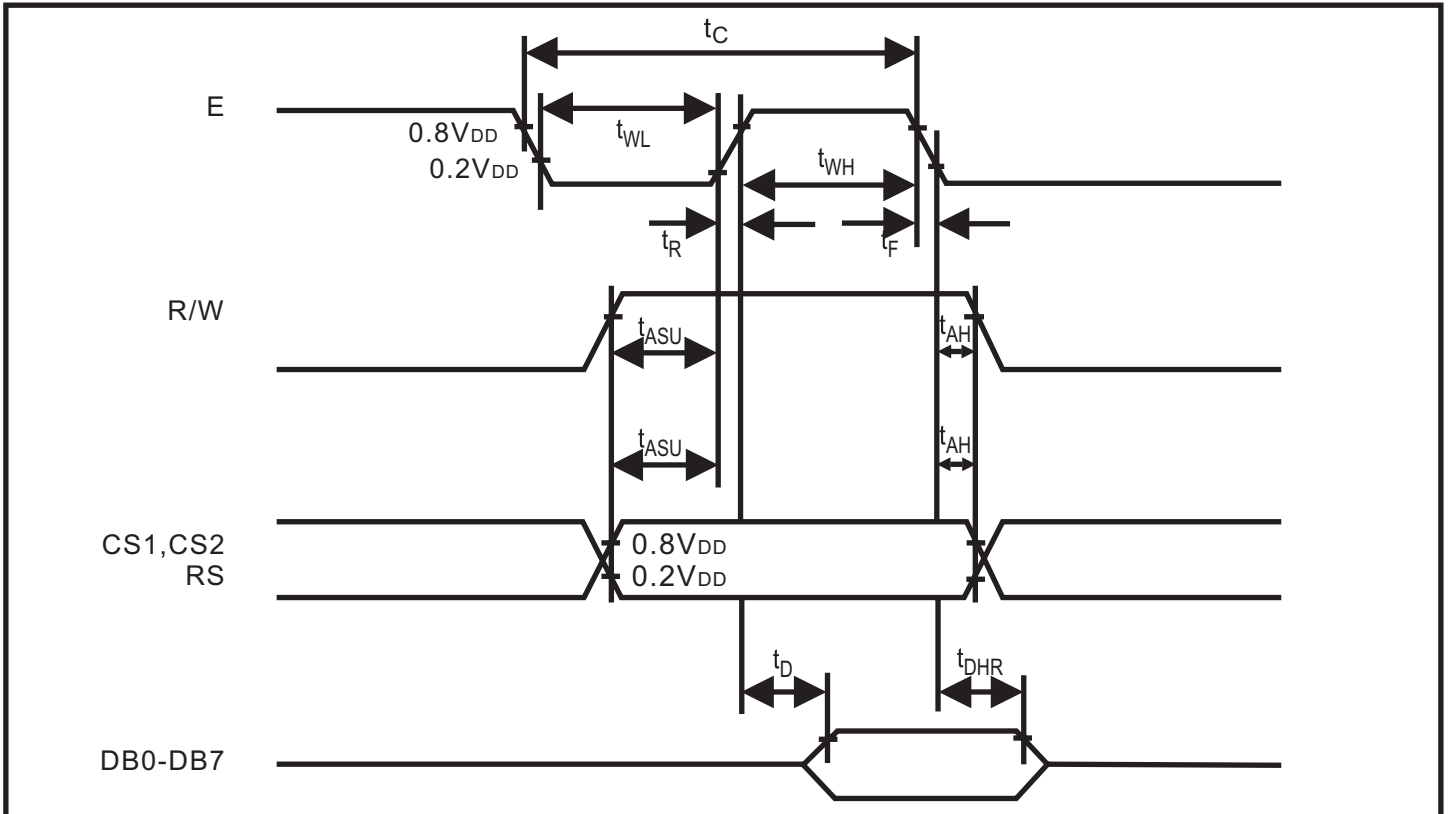



8.EXTERNAL DIMENSIONS

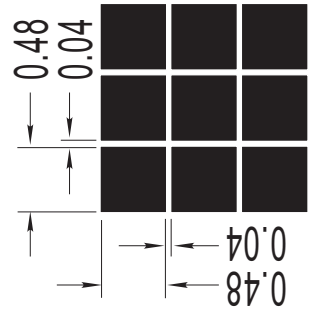
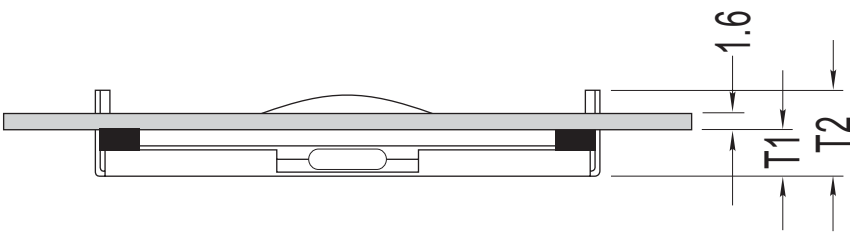
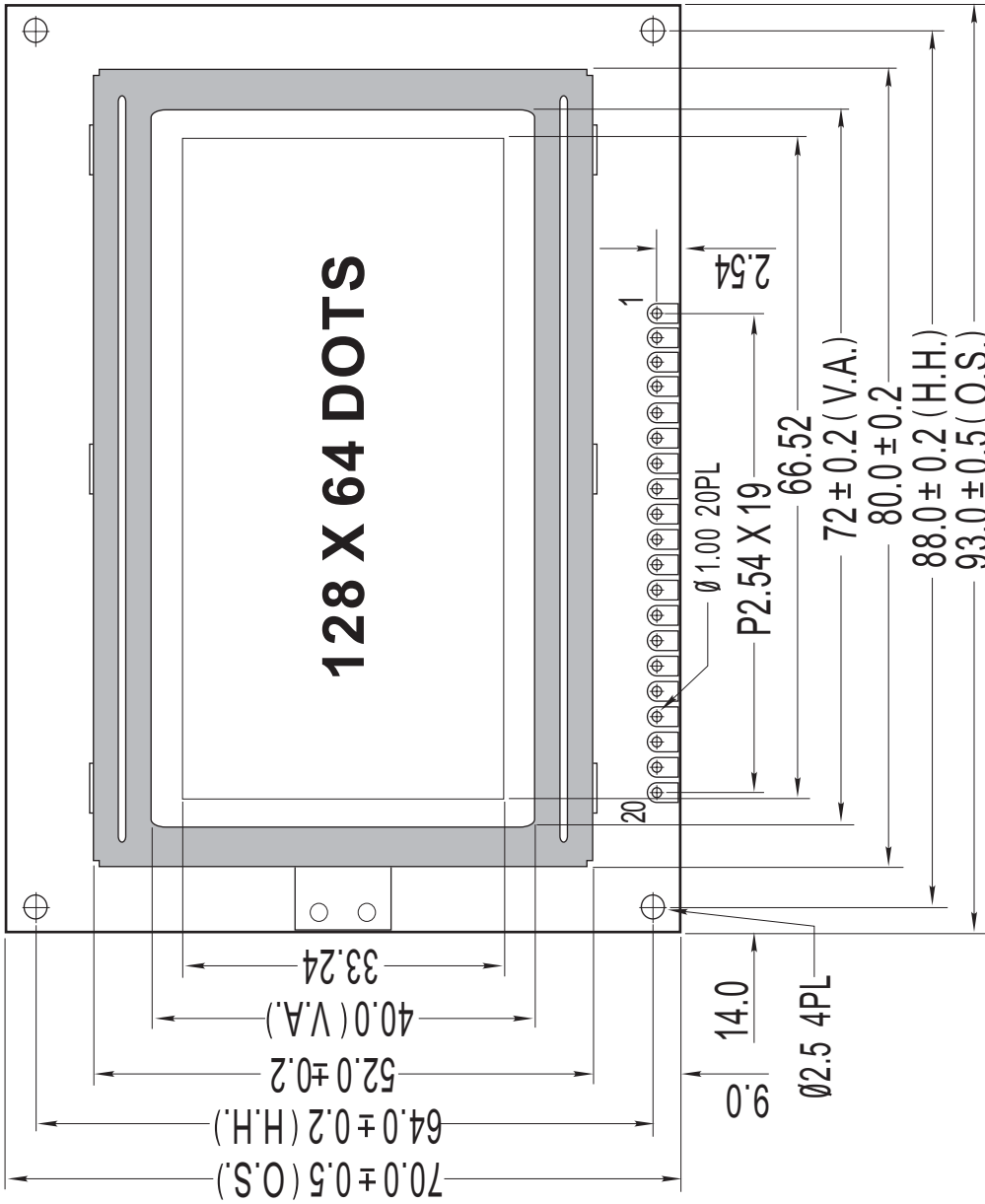

ITEM	T1	T2	UNIT
LED backlight	8.7	13.0	mm
EL or without backlight	4.6	9.0	mm

9. PIN ASSIGNMENT

PIN NO.	SYMBOL	FUNCTION	REMARK
1	Vss	Power Supply	0V
2	Vdd		+5V
3	V0		Contrast Adjust
4	RS	Register Select signal	
5	R/W	Read / Write	
6	E	Chip Enable signal	
7	DB0	Data Bit 0	
8	DB1	Data Bit 1	
9	DB2	Data Bit 2	
10	DB3	Data Bit 3	
11	DB4	Data Bit 4	
12	DB5	Data Bit 5	
13	DB6	Data Bit 6	
14	DB7	Data Bit 7	
15	CS1	When CS1=H,CS2=L, select U1	
16	CS2	When CS1=L,CS2=H, select U2	
17	RSTB	Reset signal	
18	Vee	Negative voltage output	
19	LED+	Anode of LED Unit	5.0V
20	LED-	Cathode of LED Unit	0V

10. BLOCK DIAGRAM

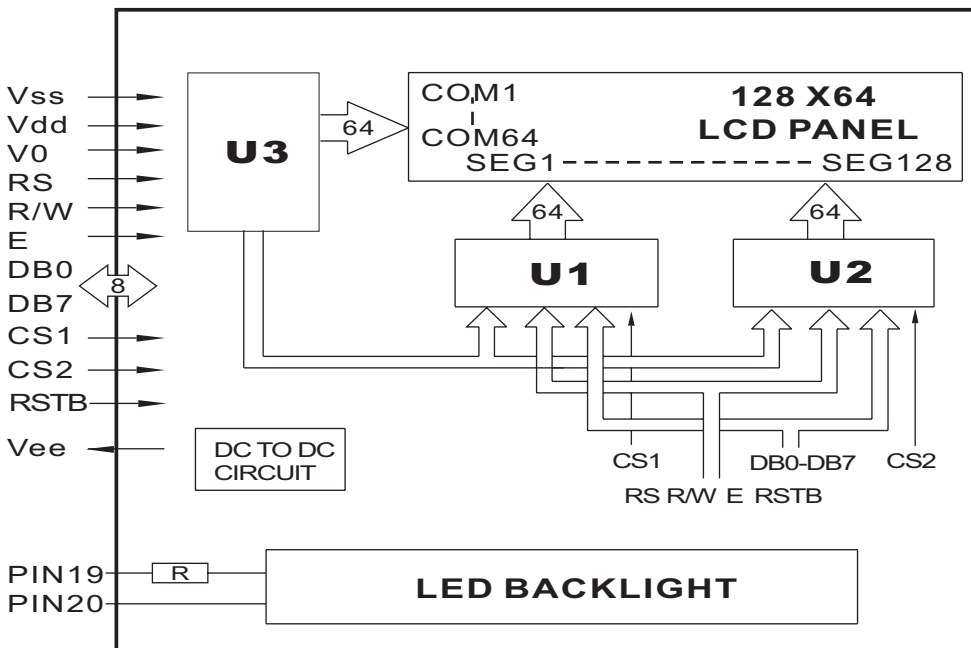

11. POWER SUPPLY

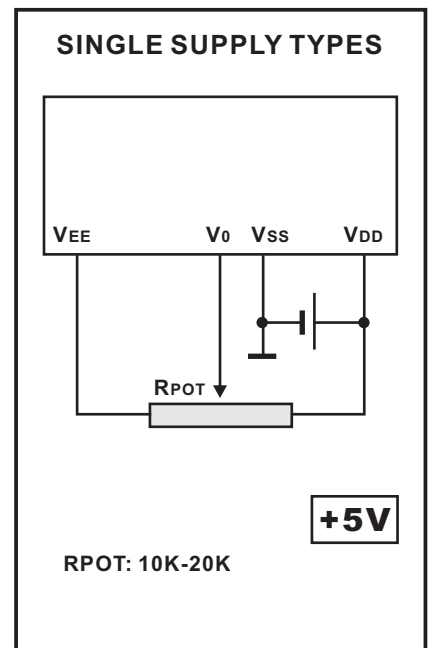



12. FUNCTIONAL DESCRIPTION

12.1 RESET

The system can be initialized by setting the RSTB to LOW when turning the power ON or by instruction from the MPU. When the RSTB is set to LOW, the following condition occurs:

1. The Display is turned OFF.
2. The Display Start Line register is set to 0 (Z-Address 0).

No instructions except the status read can be executed when the RSTB is LOW. This means that in order to execute other instructions, the RSTB must be cleared by setting DB4 to 0 and the DB7 set to 0 by status read instruction.

The table below shows the power supply initial conditions.

Parameter	Symbol	Min.	Typ.	Max.	Unit
Reset Time	t_{RS}	1.0	-	-	μS
Rise Time	t_R	-	-	200	nS

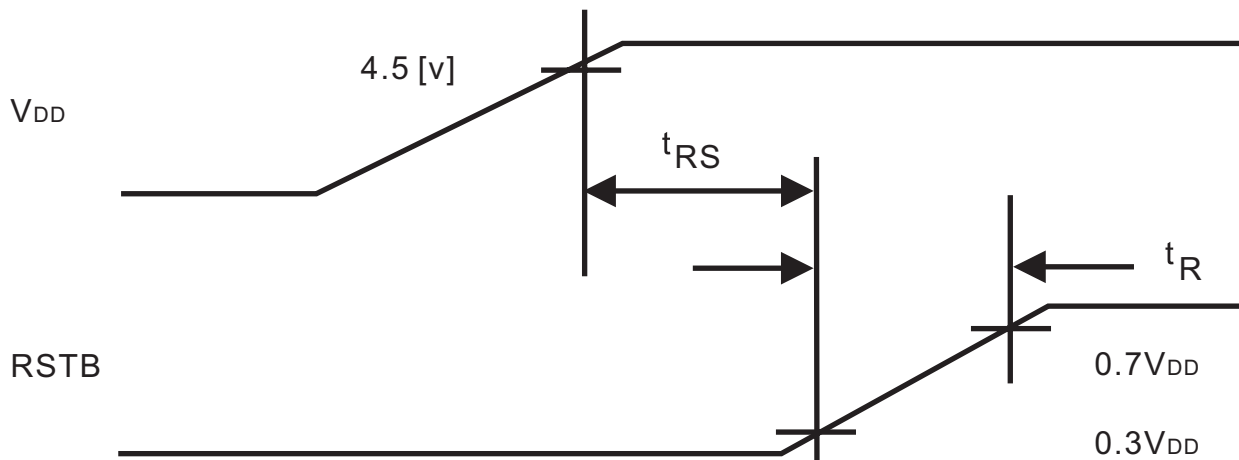



12.2 BUSY FLAG

The busy flag (DB7) is used to determine whether PT6608 is operating or not. When the busy flag is HIGH, internal operation is taking place. When the busy flag is LOW, PT6608 can accept data or instructions. The busy check diagram is shown below.

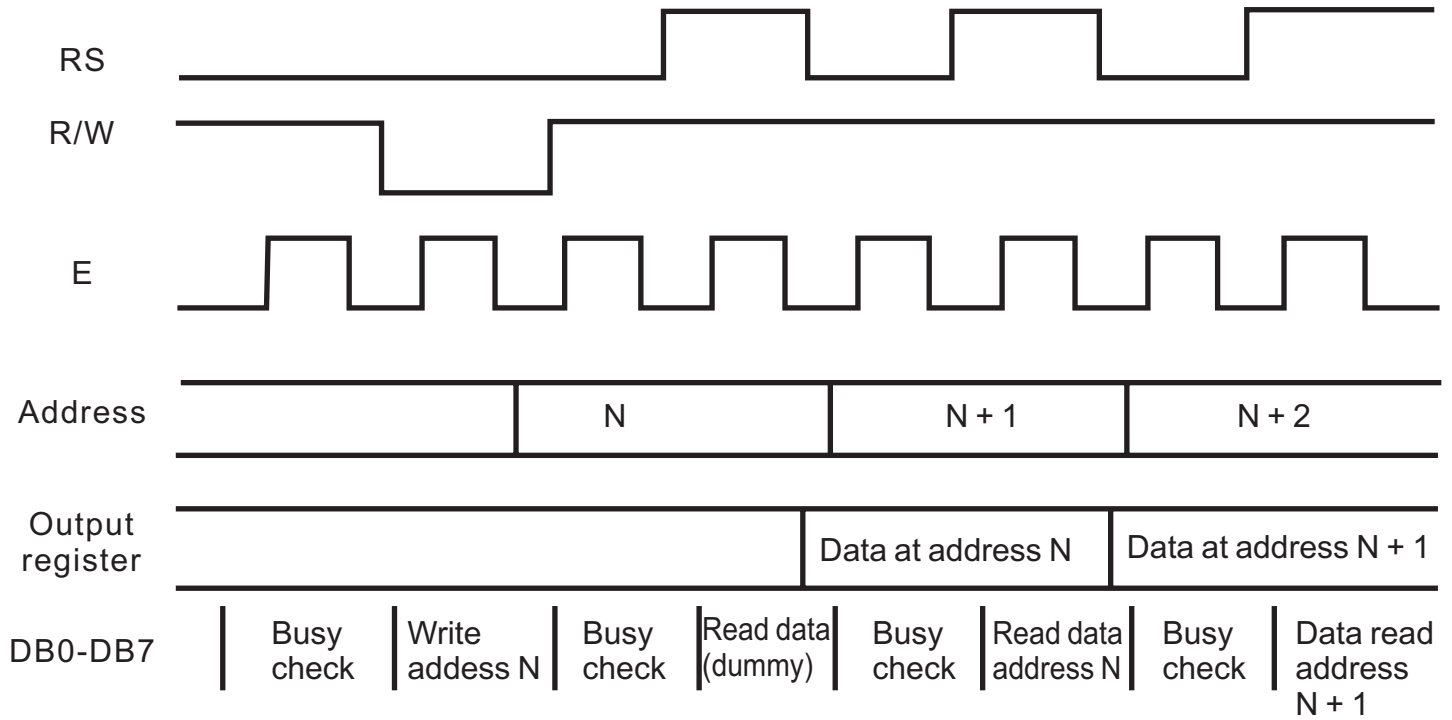

The busy flag diagram is shown below.

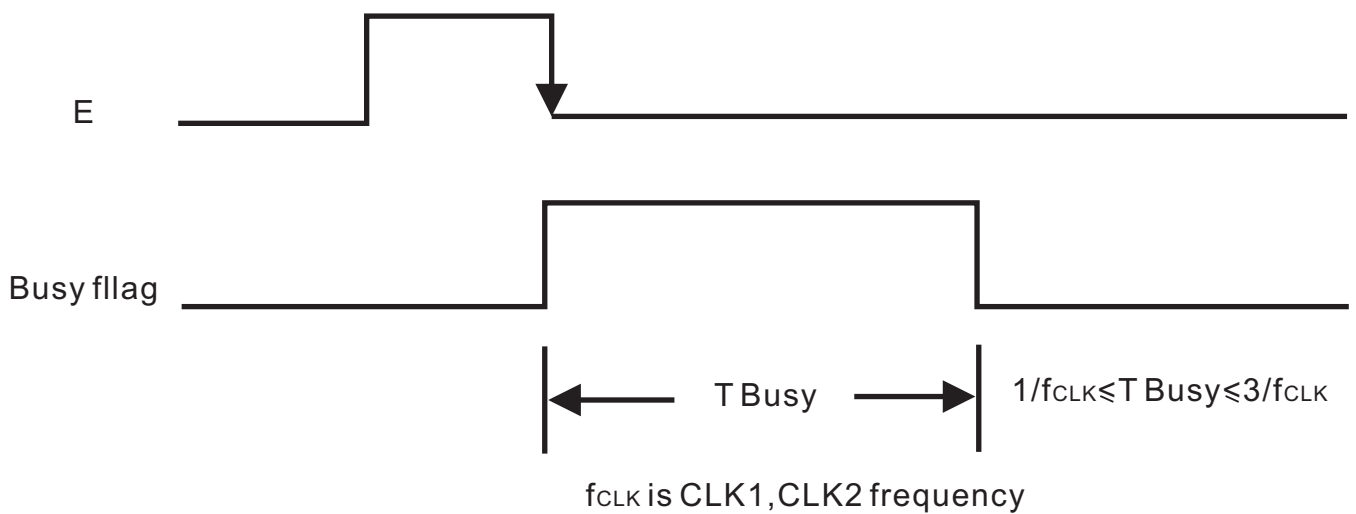



12.3 RELATION BETWEEN DISPLAY PATTERN AND DRIVERS

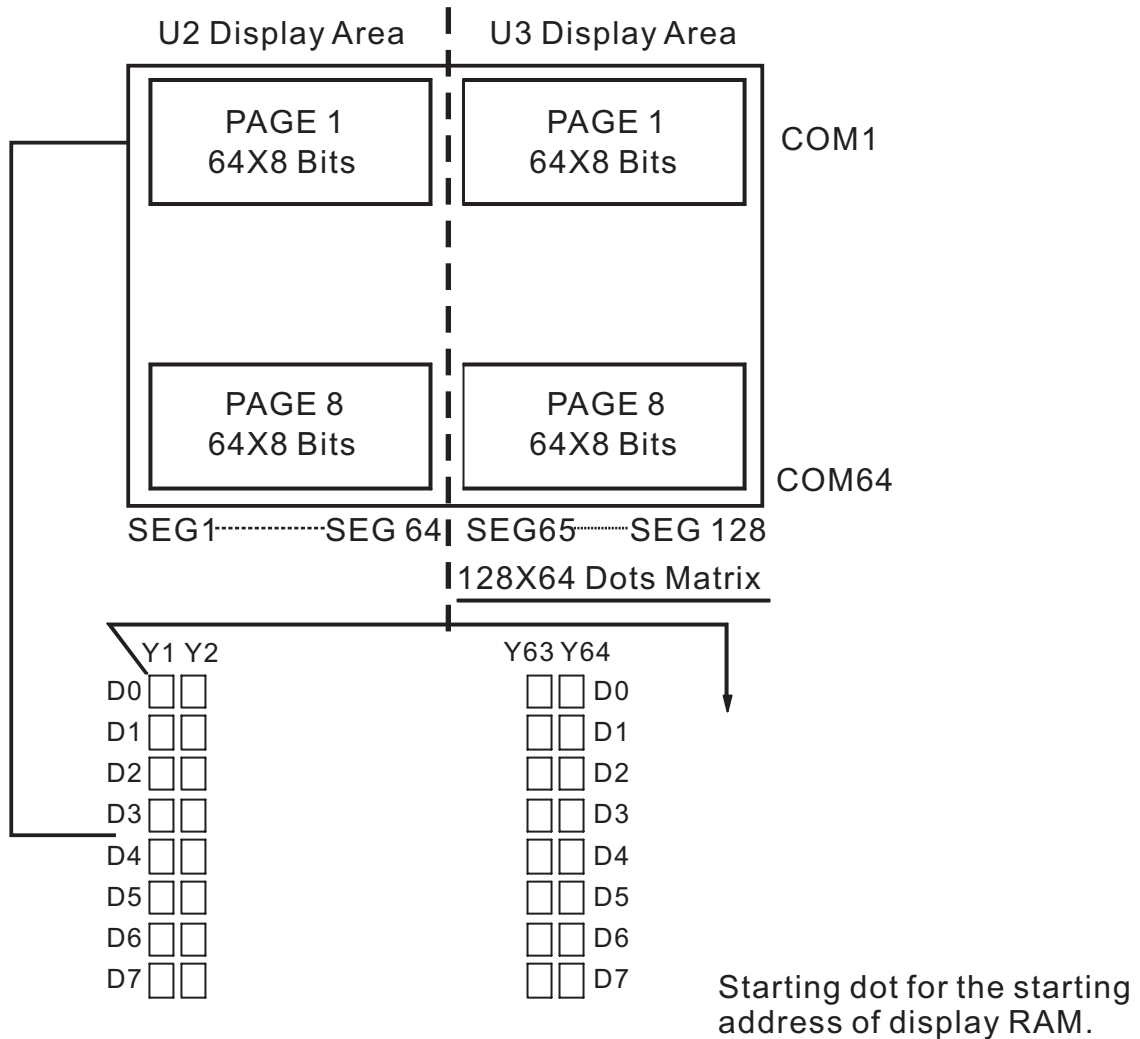

Each segment driver has 8 pages RAM, and each page has 64x8 bits RAM. D0~D7 are 8 bits transmitted data, where D0 is LSB and D7 is MSB.

12.4 DISPLAY DATA RAM

The Display Data RAM is used to store the display data for the liquid crystal display. Write data 1 is indicates an ON State of the LCDs dot matrix while the OFF State is written as 0. ADC Signal can control the Display Data RAM and the segment output. Please refer to the table below.

ADC *	Display Data
H	Y-Address 0:S1 to Y-Address 63:S64



13. INSTRUCTION

Instruction	RS	R/W	DB7	DB6	DB5	DB4	DB3	DB2	DB1	DB0	Function	
Display ON/OFF	L	L	L	L	H	H	H	H	H	L/H	Controls the display on or off. Internal status and display RAM data is not affected. L:OFF H:ON	
Set address (Y address)	L	L	L	H	Y address (0~63)						Sets the Y address in the Y address counter.	
Set Page (X address)	L	L	H	L	H	H	H	Page (0~7)			Sets the X address at the X address register.	
Display Start Line (Z address)	L	L	H	H	Display start line (0~63)						Indicates the display data RAM displayed at the top of the screen.	
Status Read	L	H	B U S Y	L	O N / O F F	R E S E T	L	L	L	L	BUSY L:Ready H:In operation ON/OFF L:Display ON H:Display OFF RESET L:Normal H:Reset	
Write Display Data	H	L	Write Data									Writes data (DB0:7) into display data RAM,After writing instruction,Y address is increased by 1 automatically.
Read Display Data	H	H	Read Data									Reads data (DB0:7) from display data RAM to the data bus.



14. DESCRIPTION OF COMMAND

Display On/Off

RS	R/W	DB7	DB6	DB5	DB4	DB3	DB2	DB1	DB0
0	0	0	0	1	1	1	1	1	D

The display data appears when D is 1 and disappears when D is 0.

Though the data is not on the screen with D=0, it remains in the display data RAM.

Therefore, you can make it appear by changing D=0 into D=1.

Set Address(Y Address)

RS	R/W	DB7	DB6	DB5	DB4	DB3	DB2	DB1	DB0
0	0	0	1	AC5	AC4	AC3	AC2	AC1	AC0

Y address (AC0-AC5) of the display data RAM is set in the Y address counter.

An address is set by instruction and increased by 1 automatically by read or write operations of display data.

Set Page(X Address)

RS	R/W	DB7	DB6	DB5	DB4	DB3	DB2	DB1	DB0
0	0	1	0	1	1	1	AC2	AC1	AC0

X address (AC0-AC2) of the display data RAM is set in the X address register.

Writing or reading to or from MPU is executed in this specified page until the next page is set.

Display Start Line(Z Address)

RS	R/W	DB7	DB6	DB5	DB4	DB3	DB2	DB1	DB0
0	0	1	1	AC5	AC4	AC3	AC2	AC1	AC0

Z address (AC0-AC5) of the display data RAM is set in the display start line register and displayed at the top of the screen.

When the display duty cycle is 1/64 or others(1/32-1/64), the data of total line number of LCD screen, from the line specified by display start line instruction, is displayed.



Status Read

RS	R/W	DB7	DB6	DB5	DB4	DB3	DB2	DB1	DB0
0	1	BUSY	0	ON/OFF	RESET	0	0	0	0

● **BUSY**

When BUSY is 1,the Chip is executing internal operation and no instructions are accepted.
 When BUSY is 0,the Chip is ready to accept any instructions.

● **ON/OFF**

When ON/OFF is 1,the display is on.
 When ON/OFF is 0,the display is off.

● **RESET**

When RESET is 1,the system is being initialized.
 In this condition, no instructions except status read can be accepted.
 When RESET is 0,initializing has finished and the system is in the usual operation condition.

Write Display Data

RS	R/W	DB7	DB6	DB5	DB4	DB3	DB2	DB1	DB0
1	0	D7	D6	D5	D4	D3	D2	D1	D0

Writes data (D0-D7) into the display data RAM.
 After writing instruction, Y address is increased by 1 automatically.

Read Display Data

RS	R/W	DB7	DB6	DB5	DB4	DB3	DB2	DB1	DB0
1	1	D7	D6	D5	D4	D3	D2	D1	D0

Reads data (D0-D7) from the display data RAM.
 After reading instruction, Y address is increased by 1 automatically.

 FORDATA ELECTRONIC CO.,LTD PROFESSIONAL LCD SUPPLIER FROM CHINA	PRODUCT SPEC.	MODE NO.	PAGE 16/17
		FDCG12864B-NSWBBW-51XN	

15. APPLICATION EXAMPLE

Application Flowchart

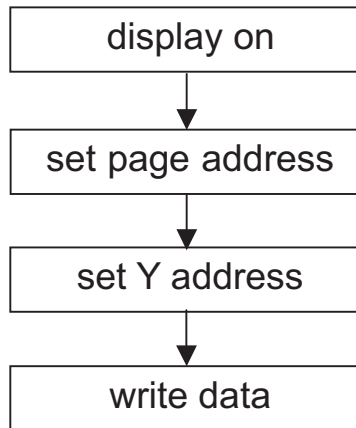

Application Circuit

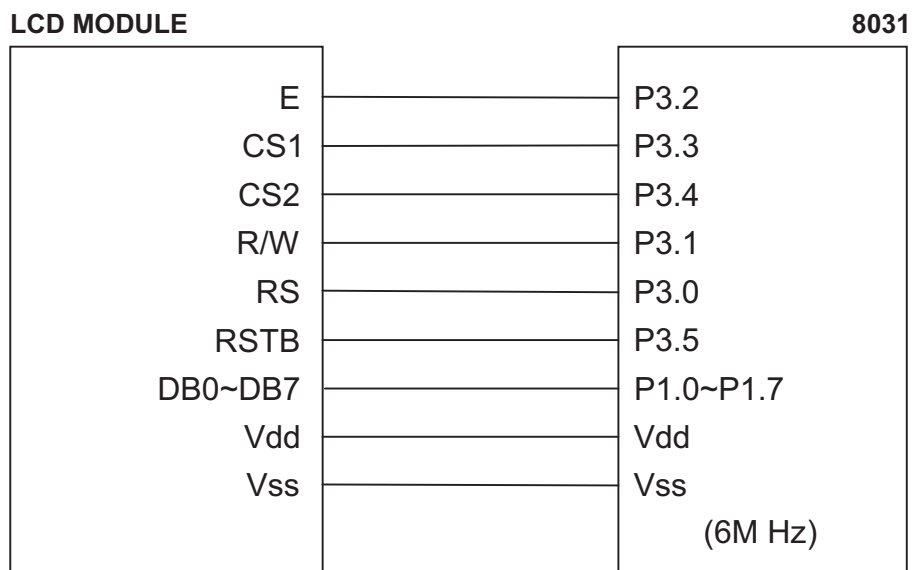

 FORDATA ELECTRONIC CO.,LTD PROFESSIONAL LCD SUPPLIER FROM CHINA	PRODUCT SPEC.	MODE NO.	PAGE 17/17
		FDCG12864B-NSWBBW-51XN	

16. PACKING DETAIL

WITH LED BKL	WITHOUT LED BKL
30 PCS/BOX	30 PCS/BOX
8 BOXES/CARTON	8 BOXES/CARTON
240 PCS/CARTON	240 PCS/CARTON
19.00 KGS/CTN(G.W.)	19.00 KGS/CTN(G.W.)
0.07 M ³ /CARTON	0.07 M ³ /CARTON

NOTE
1. The weight is estimated for reference only.
2. Packing detail may be changed without notice.
3. FORDATA prefer 240PCS order quantity to 250PCS for full packing cause.

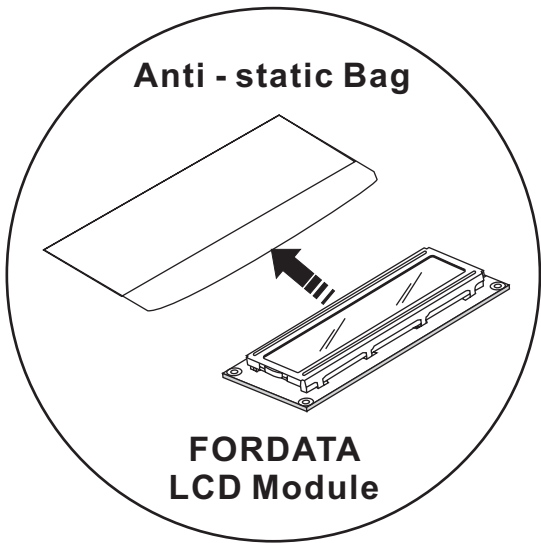

BOX 

CARTON 

