

Ultrasonic distance sensor module

DYP-ME007YY –V2.0

High performance waterproof ultrasonic sensor module:

UART output format

PWM output format

KG output format



Ultrasonic distance sensor module of DYP-ME007YY V2.0 uses the separated type and enclosed waterproof ultrasonic transducer, which has a certain dust waterproof level, suitable for the wet and poor measurement occasions. Small blind zone (3cm) which is suitable is different testing conditions and the operation is simple, it's a commercial grade module with high-performance and high reliability.

Our company reserves the right to revise the document and update function, no notice!

Features:

- 1) Blind zone: 3cm;
- 2) Power supply: 5V;
- 3) Working current: less than 15mA;
- 4) UART auto-output;
- 5) PWM controlled output;
- 6) Digital output;
- 7) Enclosed separated type ultrasonic transducer;
- 8) Center frequency: 40KHz;
- 9) Working temperature: -15°C to +60°C;
- 10) Storage temperature: -25°C to +80°C;
- 11) Measurement accuracy: $\pm(1\text{cm}+S*0.3\%)$
(S is measured value)
- 13) Electrostatic protective design, the enclosure of sensor and the I/O pin are added the electrostatic protection device, up to the standard of IEC61000-4-2;

Advantage:

- 1) Small blind zone;
- 2) Strong anti-interference;
- 3) Data output, stable and reliable;
- 4) Lower power dissipation;
- 5) Fast response time;
- 6) Strong antistatic;
- 7) Wide working temperature;
- 8) High measurement accuracy;
- 9) With auto-output mode, release the processor of user;
- 10) With controlled output mode, could minimize power consumption according to the actual application;

Application:

- 1) Level distance measurement;
- 2) Parking management system;
- 3) Robot obstacle avoidance 、 automatic control;
- 4) Detect the objects close to and the existence of external objects;

Ultrasonic sensor

Ultrasonic sensor module is with air as medium, non-contact target detection and distance measurement, detection object in an area. This sensor is not affected by color or other visual from the detected object. The ultrasonic sensor sends out high frequency sound waves in the environment of the detection, meanwhile receive the reflection of the ultrasonic echo from nearby objects and directly output distance reading through processing the echo time.

Distance measurement

If you want to get a 100% reliable and stable distance value, you had to be sure the measured object is in the scope of the sensor's effective range. Most users found sensor is in the blind zone or outside the range also could be measured that was because of the physical characteristics of ultrasonic, aim at different measuring objects, we don't guarantee the accuracy of the measuring distance.

Basic parameter:

Parameters item	PWM output	UART output	KG output	Unit	Remark
Working voltage	5	5	5	V	DC
Average working current	≤15	≤15	≤15	mA	(1)
Peak current	60	60	60	mA	
Blind distance	0-3	0-3	0-3	cm	
Flat object range	3-420	3-420	3-420	cm	(2)
Work cycle	Controlled	100	100	ms	
Output mode	PWM pulse width	UART serial port	TTL level digital		(3)
Room temperature measurement precision	±(1+S*0.5%)	±(1+S*0.3%)	±(1+S*0.3%)	cm	(2)
The center frequency of sensor	40K±1.0K	40K±1.0K	40K±1.0K	Hz	
ESD	±4/±8	±4/±8	±4/±8	KV	(4)
Temperature compensation	No compensation	compensation	compensation	-	
Working temperature	-15~60	-15~60	-15~60	°C	
Storage temperature	-25~80	-25~80	-25~80	°C	
Working humidity	≤80%	≤80%	≤80%	RH	(5)
Storage humidity	≤90%	≤90%	≤90%	RH	(5)

Note:

- 1) The typical data of work cycle with 100ms;
- 2) Above measured data are from the plane of carton with 50cm * 60cm;
- 3) The output mode of UART/KG/PWM is optional, must be confirmed before delivery, user could choose one of output only, two or more output modes cannot coexist;
- 4) The enclosure of sensor and the connecting leads are up to the standard of IEC61000-4-2
- 5) a, when the environment temperature is in 0-39°C, the maximum value of humidity is 90%(no condensation);
b, when the environment temperature is in 40-50°C, the maximum value of humidity is the high humidity in the natural world under current temperature(no condensation);

Output pin definition:

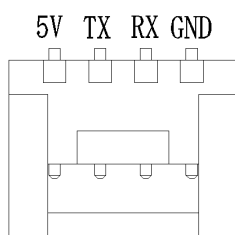

Pin number	Pin name	Pin description		Remark
1	5V	5V supply voltage input pin		
2	TX	UART/PWM/KG output pin		(1)
3	RX	UART	The wire for choosing the processing value and the real time value output	(1)
		KG	The wire for choosing the processing value and the real time value output	
		PWM	The wire for trigger input	
4	GND	GND		

Remark: The pin function is corresponding to the output mode, which user choose before delivery, and cannot coexist with other output methods.

Output format of UART

1) Communication instructions of UART

When the input leads "RX" is hung in air or input high level, sensor will output according to the processing value, which data is more stable and the response time is about 100-300ms; when input low level, sensor will output according to the real-time value, and the response time is 100ms.

UART	Data bits	Stop bit	Parity check	Baud rate
TTL level	8	1	none	9600bps

2) Output format of UART

Frame data	Instructions	Byte
Frame header	Fixed to 0XFF	1 byte
Data_H	High 8 bits of distance data	1 byte
Data_L	Low 8 bits of distance data	1 byte
SUM	Checksum of communication	1 byte

3) Example of UART output

Frame data	Data_H	Data_L	SUM
0XFF	0X07	0XA1	0XA7

Note: The checksum retains the low 8 bits of accumulative value only;

$$\text{SUM} = (\text{Frame data} + \text{Data}_H + \text{Data}_L) \& 0x00FF$$

$$= (0XFF + 0X07 + 0XA1) \& 0x00FF$$

$$= 0XA7;$$

$$\text{Distance value} = \text{Data}_H * 256 + \text{Data}_L = 0X07A1;$$

Converted to a decimal is 1953;

Means the current measured distance value is 1953mm;

Output format of KG

1) The positive output of digital output

When module could detect object in the detection range, the output leads "TX" will output a high level(VCC), and if could not detect anything in the detection range it'll output a low level(GND). This module output a high/low level signal only, without drive capacity.

2) The negative output of digital output

When module could detect object in the detection range, the input leads "TX" will output a low level(GND), and if could not detect anything in the detection range it'll output a high level(VCC). This module output a high/low level signal only, without drive capacity.

3) Default parameters

- ① We default the output mode is positive output and threshold value of induction area is 100cm ;
- ② When the trigger input leads "RX" is hung in air or inputs high level, the module will output according to the processing value, which data is more stable and the response time is about 100-300ms, delay time is 500ms-1500ms; When it inputs low level, module will output according to the real-time value, and the response time is 100ms and delay time is 500ms;

Output format of PWM

1) Trigger instructions

When the trigger input leads - "RX" receives a high level trigger pulse, falling edge will trigger module to work one time, output leads - "TX" will output one TTL level of PWM high level pulse width signal, the trigger cycle of module must be more than 60ms, if module did not detect anything the output pin will output a fixed pulse width, which is about 35ms;

2) Timing diagrams

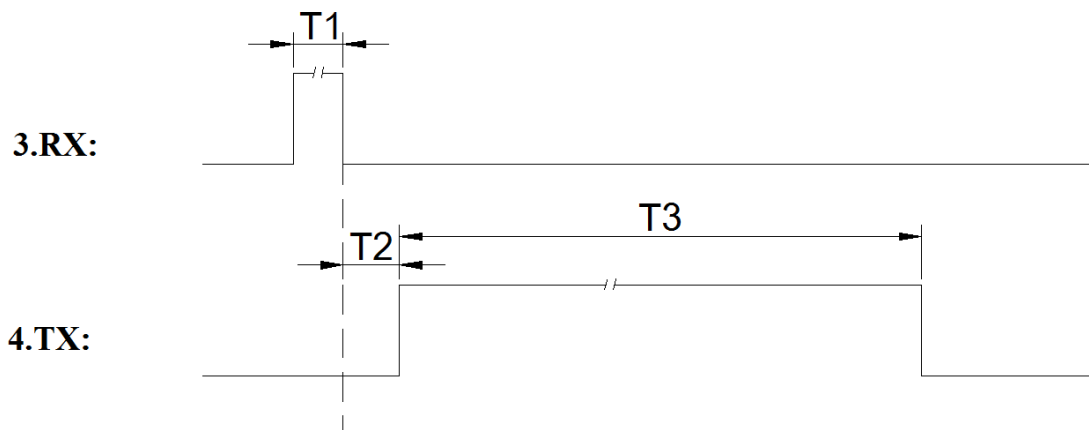

Note: T1=0.1~10MS ; T2=4~5MS ; T3=1.3~35MS (the time of PWM high level pulse width)

3) Compute mode

Formula: $S=T*V/2$ (S is distance value, T is the time of PWM high level pulse width, V is sound travels in air)

The sound velocity is 344m/s at room temperature, and the formula could be simplified to $S=T/58$ (now the unit of distance "S" is cm, unit of time "T" is microsecond).

For example, when the output pin "TX", which time of PWM high level pulse width T3 is 10000us, and $S=T/58=10000/58\approx 172.4$ (cm), means the current value of measured distance is 172.4cm;

Mechanical features:

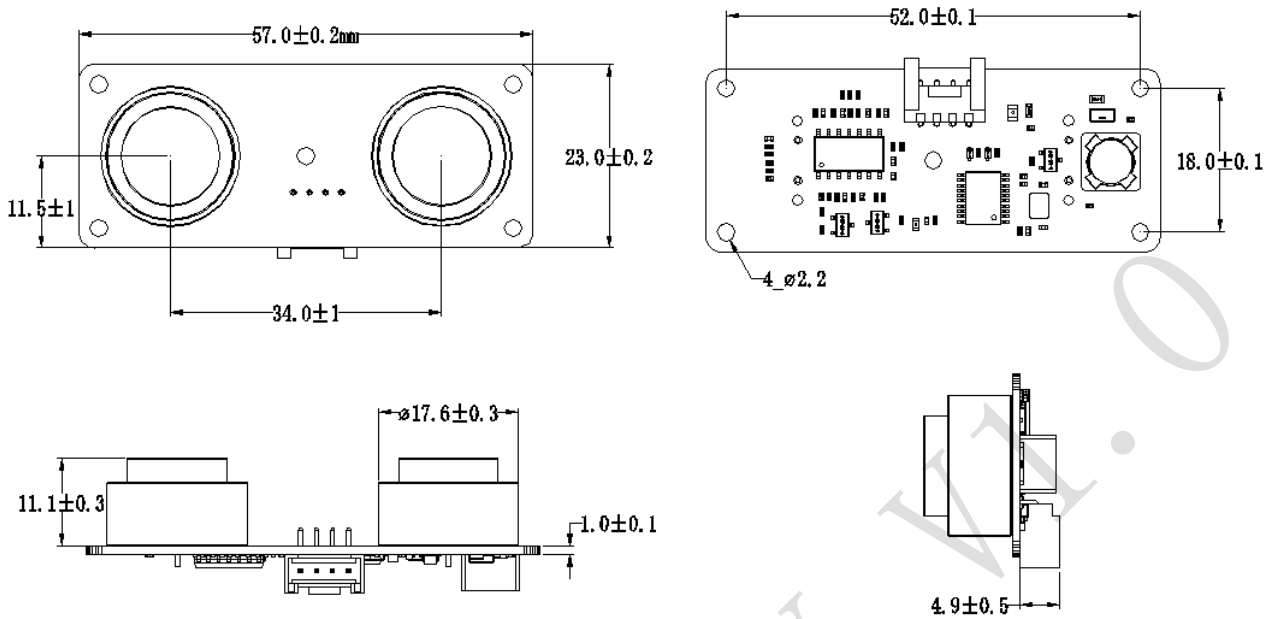

unit:mm

The effective detection range

1) The tested object is the white cylindrical tube, material is PVC, height is 100cm, diameter is 75mm;

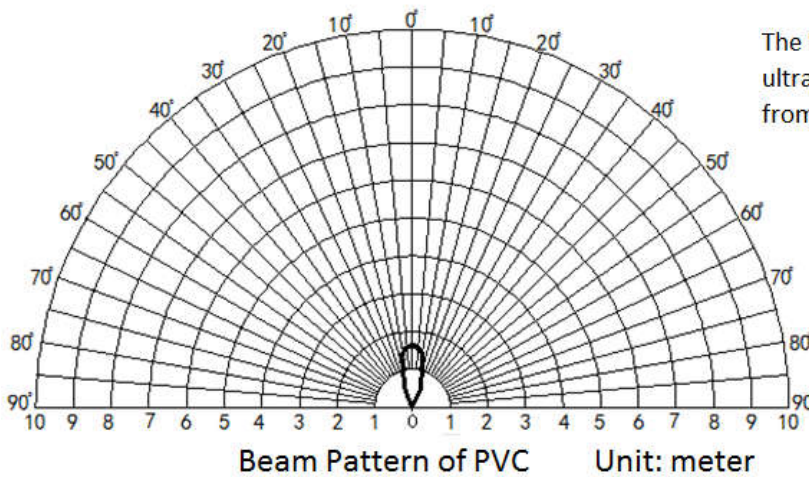

The PVC tube is parallel to the ultrasonic transducer and moved from left to right.

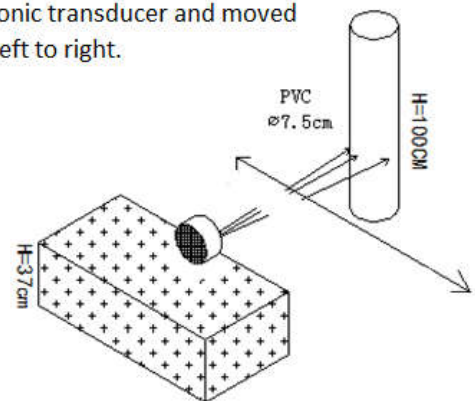

2) The tested object is the corrugated case, perpendicular to 0° axle wire, length is 60cm, width is 50cm;

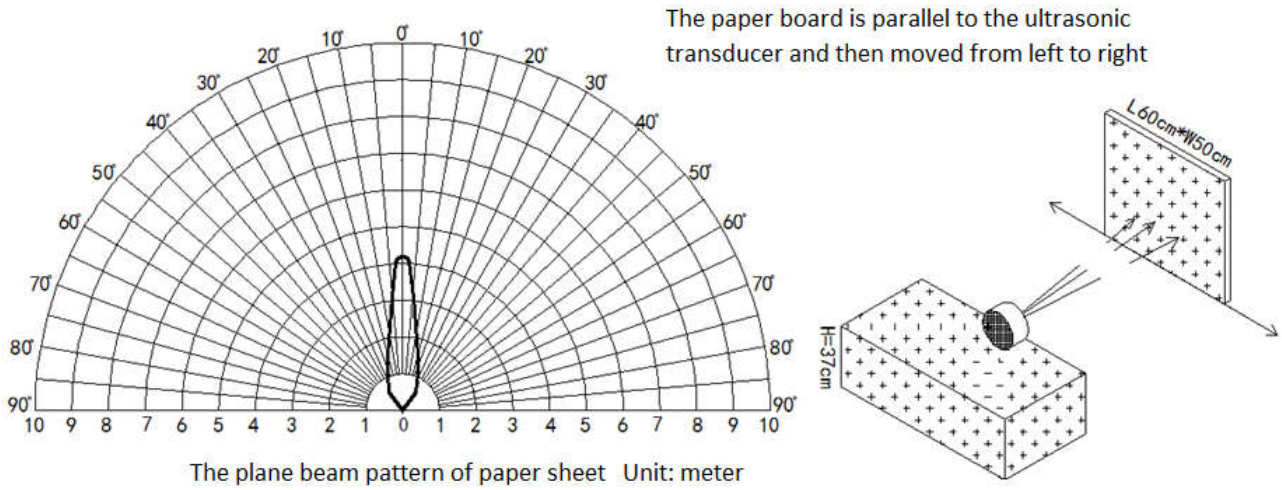

4) The tested object is the corrugated case and tangent to arc, length is 60cm, width is 50cm;

